

HITACHI
Inspire the Next

L200 Series

Variable Frequency Drive

Ecology
Compact
Easy Inverter



Compact, full-featured new generation

Empowered with cutting-edge functions yet easy-to-install, L200 series delivers a modern, global variable frequency drive

L200 Series

VARIABLE FREQUENCY DRIVE

1

Operation Source Switch

Run command/frequency source are easy to select with a DIP switch. Default is keypad settings. Sliding the switch changes the sources to the control terminals.

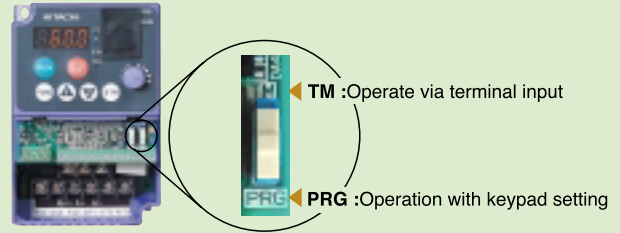

2

Improved PID Control

Reverse PID function changes the sign of the deviation value which is the difference between target and feedback values. Upper and lower limits from a target value can be imposed on the inverter output frequency.

3

Logic and Output Timing functions

Output terminals can be assigned logical operators AND, OR and XOR with RUN, AL and so on. ON and OFF delay times are settable for each output terminal. Allows for more flexible system design.

4

Analog Setpoint Calculate Functions

An offset frequency can be added to or subtracted from the output frequency when ADD terminal is ON. For example, if output frequency setting is 40Hz and offset frequency is 5Hz, output frequency becomes 45Hz (or 35Hz) when ADD terminal is ON.

Model Configuration

Applicable Motor kW (HP)	1-/3-phase 200V class			3-phase 400V class	
	US version	European version	JP version	US version	European version
0.2(1/4)	L200-002NFU	L200-002NFEF	L200-002LFR		
0.4(1/2)	L200-004NFU	L200-004NFEF	L200-004LFR	L200-004HFU	L200-004HFEF
0.55(3/4)		L200-005NFEF			
0.75(1)	L200-007NFU	L200-007NFEF	L200-007LFR	L200-007HFU	L200-007HFEF
1.1(1.5)		L200-011NFEF			
1.5(2)	L200-015NFU	L200-015NFEF	L200-015LFR	L200-015HFU	L200-015HFEF
2.2(3)	L200-022NFU	L200-022NFEF	L200-022LFR	L200-022HFU	L200-022HFEF
3.0(4)					L200-030HFEF
3.7(5)	L200-037LFU		L200-037LFR		
4.0(5)				L200-040HFU	L200-040HFEF
5.5(7.5)	L200-055LFU		L200-055LFR	L200-055HFU	L200-055HFEF
7.5(10)	L200-075LFU		L200-075LFR	L200-075HFU	L200-075HFEF

drive
easy-to-use, easy-to-maintain.
solution.



L200-***EF Type

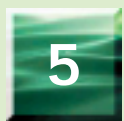

Integrated EMC Filter

Reduces electromagnetic noise. (on European-Version unit only. Effective for only single phase input for 200V class models)



Easy Maintenance

Detachable cooling-fan.

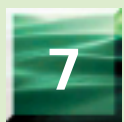

RS-485 Serial Port

An RS-485 communication port with Modbus®-RTU protocol is integrated. Easier for network operation.

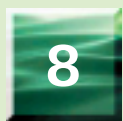
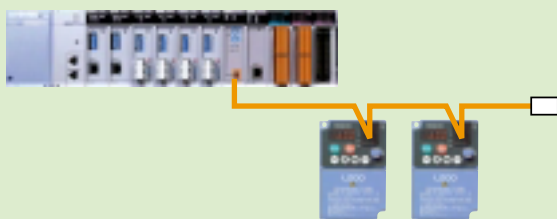

Versatile Functions

- Pure analog monitor output (8-bit, 0-10V DC)
- External thermistor terminal (PTC)
- Side-by-side installation
- Second motor setting
- Over-voltage suppression at deceleration
- 3-wire control
- Analog input selection
- Second acceleration/deceleration setting
- Jogging
- Unattended start protection (USP)
- Analog input wire-break detection

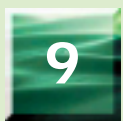

Global Performance

Conformity to global standards. CE, UL, c-UL and c-Tick approvals.



<p>ISO 14001 EC97J1095</p>	<p>Hitachi variable frequency drives (inverters) in this brochure are produced at the factory registered under the ISO 14001 standard for environmental management system and the ISO 9001 standard for inverter quality management system.</p>
<p>ISO 9001 JQA-1153</p>	

Model Name Indication

L200-004 H F E F

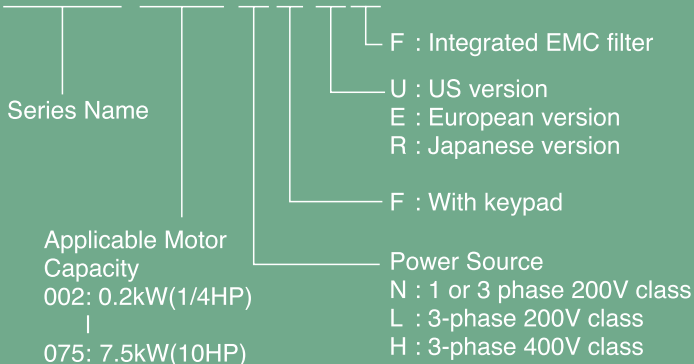

Standard Specifications

1-/3-phase 200V class

Model L200-		European Version	002NFEF	004NFEF	005NFEF	007NFEF	011NFEF	015NFEF	022NFEF	-	-	-	
		US Version	002NFU	004NFU	-	007NFU	-	015NFU	022NFU	037LFU	055LFU	075LFU	
Output Ratings	Applicable motor size, 4-pole kW(HP) *1		0.2(1/4)	0.4(1/2)	0.55(3/4)	0.75(1)	1.1(1.5)	1.5(2)	2.2(3)	3.7(5)	5.5(7.5)	7.5(10)	
	Rated capacity	200V	0.5	0.9	1.0	1.4	1.7	2.5	3.5	5.5	7.5	11	
		240V	0.5	1.0	1.2	1.6	2.0	2.9	4.1	6.6	9.9	13.3	
	Rated output current (A) *2		1.4	2.6	3.0	4.0	5.0	7.1	10.0	15.9	24	32	
	Overload capacity(output current)		150% for 60sec										
Rated output voltage (V)		3-phase (3-wire) 200 to 240V (proportional to input voltage)											
Input Rating	Rated input voltage (V)		1-/3-phase 200 to 240V +/-10%, 50/60Hz +/-5%								3-phase 200 to 240V +/-10%, 50/60Hz +/-5%		
Protective enclosure			IP20										
Cooling method			Self-cooling				Force ventilation						
Weight (kg)	-HFEF		0.8	0.95	0.95	1.4	1.4	1.9	1.9	-	-	-	
	-NFU/LFU		0.7	0.85	-	1.3	-	1.8	1.8	1.9	3.5	3.5	

3-phase 400V class

Model L200-		European Version	004HFEF	007HFEF	015HFEF	022HFEF	030HFEF	040HFEF	055HFEF	075HFEF	
		US Version	004HFU	007HFU	015HFU	022HFU	-	040HFU	055HFU	075HFU	
Output Ratings	Applicable motor size, 4-pole kW(HP) *1		0.4(1/2)	0.75(1)	1.5(2)	2.2(3)	3(4)	4.0(5)	5.5(7.5)	7.5(10)	
	Rated capacity	200V	1.0	1.7	2.6	3.8	5.4	5.9	7.5	11	
		240V	1.1	1.9	2.9	4.2	6.2	6.6	10.3	12.7	
	Rated output current (A) *2		1.5	2.5	3.8	5.5	7.8	8.6	13	16	
	Overload capacity(output current)		150% for 60sec								
Rated output voltage (V)		3-phase (3-wire) 380 to 480V (proportional to input voltage)									
Input Rating	Rated input voltage (V)		3-phase 380 to 480V +/-10%, 50/60Hz +/-5%								
Protective enclosure			IP20								
Cooling method			Self-cooling				Force ventilation				
Weight (kg)	-HFEF		1.4	1.8	1.9	1.9	1.9	1.9	3.8	3.8	
	-NFU/LFU		0.7	0.7	1.8	1.8	-	1.8	3.5	3.5	

General Specifications

Item		General Specifications	
Control	Control method	Line-to-line sine wave pulse-width modulation (PWM) control	
	Output frequency range *5	0.5 to 400Hz	
	Frequency accuracy *6	Digital command :±0.01%, Analog command±0.2% (25±10°C)	
	Frequency setting resolution	Digital: 0.1Hz, Analog: (max frequency)/1000	
	Voltage/Frequency Characteristic	V/f control, V/f variable (constant torque, reduced torque)	
	Acceleration/deceleration time	0.01 to 3000 sec., (linear, sigmoid), two-stage accel./decel.	
	Carrier frequency range	2.0 to 14.0kHz	
Input terminal	Protective functions	Over-current, over-voltage, under-voltage, overload, overheat, ground fault at power-on, overload limit, input over-voltage, external trip, EEPROM error, CPU error, USP error, LAD stop at over-voltage, over-current suppression	
	Specification	4.7kohm input impedance, sink/source logic selectable	
Output signal	Functions	FW(Forward), RV(Reverse), CF1-CF4(Multispeed command), JG(Jogging), DB(External DC braking), SET(Second motor constants setting), 2CH(Second accel./decel.), FRS(Free-run stop), EXT(External trip), USP(Unattended start protection), SFT(Software lock), AT(Analog input selection), RS(Reset), PTC(Thermistor input) *7, STA(3-wire start), STP(3-wire stop), F/R(3-wire fwd./rev.), PID(PID On/Off), PIDC(PID reset), UP/DWN(Remote-controlled accel./decel.), UDC(Remote-controlled data clearing), OPE(Operator control), NO(Not selected)	
	Intelligent output terminal	Specification	27V DC 50mA max open collector output, 2 terminals 1c output 250V AC/30V DC 2.5A relay (AL0, AL1, AL2 terminals)
Operator	Analog output terminal	Function	RUN(run signal), FA1(Frequency arrival type 1 - constant speed), FA2(Frequency arrival type 2 - over-frequency), OL(overload advance notice signal), OD(Output deviation for PID control), AL(alarm signal), DC(Wire brake detect on analog input)
	Display	Specification	4-digits 7 segment LEDs
Operation	Status LED Interface	Function	Parameter setting, output frequency, output current, motor torque, scaled value of output frequency, trip history, I/O terminal condition, input power, output voltage
	Frequency setting	Operator keypad	Power, Alarm, Run, Prg, Hz and A Potentiometer, RUN, STOP/RESET, UP, DOWN, FUN and STR keys
		External signal	Up and Down keys / Value settings or analog setting via potentiometer on operator keypad
	FW/RV Run	Serial port	0 to 10 V DC, 4 to 20 mA
Operator keypad		RS485 interface (Modbus RTU)	
Environment	Humidity	External signal	Run key / Stop key (change FW/RV by function command)
		Serial port	FW Run/Stop (NO contact), RV set by terminal assignment (NC/NO), 3-wire input available
	Vibration	RS485 interface (Modbus RTU)	
	Location		
Other functions		-10 to 40°C(derating for output frequency is required if carrier frequency exceeds 5kHz) -25 to 70°C 20 to 90% RH 5.9mm/s ² (0.6G) 10 to 55Hz Altitude 1,000 m or less, indoors (no corrosive gasses or dust)	
Coating color		AVR (Automatic Voltage Regulation), V/f characteristic selection, accel./decel. curve selection, frequency upper/lower limit, 16 stage multispeed, PID control, frequency jump, external frequency input bias start/end, jogging, automatic torque boost, trip history etc.	
Options		Blue (DIC14 Version NO.436) Remote operator with copy function (SRW-0EX), EMI filters, input/output reactors, DC reactors, radio noise filters, braking resistors, braking units, LCR filter, communication cables (ICS-1, 3), programming software (being planned)	

- Note 1: The applicable motor refers to Hitachi standard 3-phase motor (4-pole). When using other motors, care must be taken to prevent the rated motor current (50/60 Hz) from exceeding the rated output current of the inverter.
- Note 2: The output voltage decreases as the main supply voltage decreases (except when using the AVR function). In any case, the output voltage cannot exceed the input power supply voltage.
- Note 3: The braking torque via capacitive feedback is the average deceleration torque at the shortest deceleration (stopping from 50/60 Hz as indicated). It is not continuous regenerative braking torque. The average decel torque varies with motor loss. This value decreases when operating beyond 50 Hz. If a large regenerative torque is required, the optional regenerative braking unit should be used.
- Note 4: The protection method conforms to JEM 1030.
- Note 5: To operate the motor beyond 50/60 Hz, consult the motor manufacturer for the maximum allowable rotation speed.
- Note 6: The output frequency may exceed the maximum frequency setting (A004 or A024) for automatic stabilization control.
- Note 7: Only terminal 5 is assignable the PTC (thermistor) function.

Dimensions

•L200-002 - 004NFU

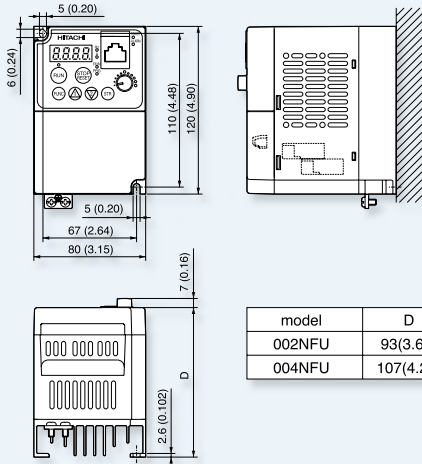

•L200-002 - 005NFEF

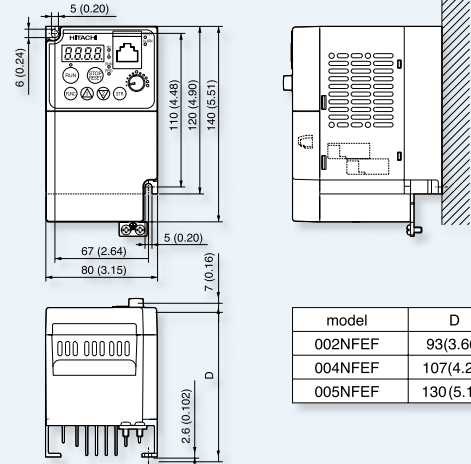

[Unit : mm (inch)]
Inches for reference only.

•L200-007 - 022NFU, 037LFU •L200-004 - 040HFU

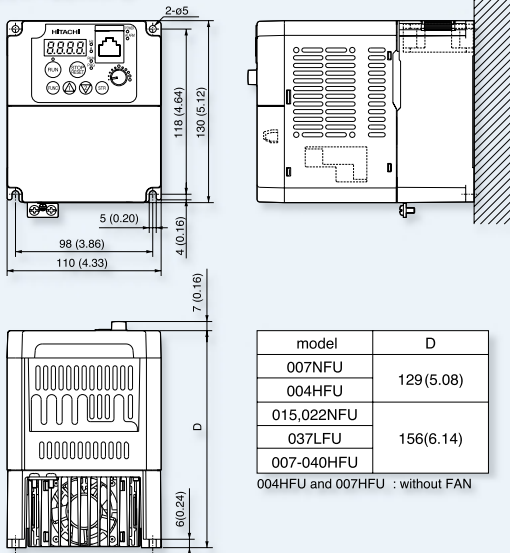

•L200-007 - 022NFEF •L200-004 - 040HFEF

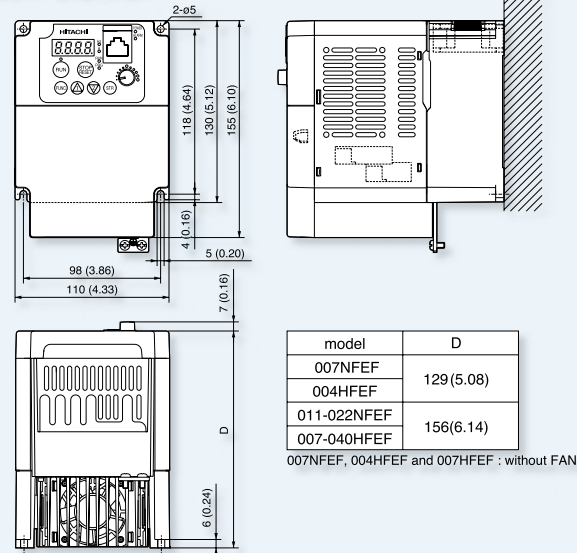

•L200-055,075LFU •L200-055,075HFU

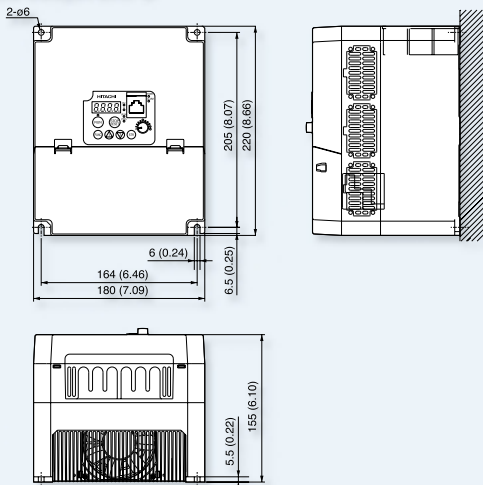

•L200-055,075HFEF

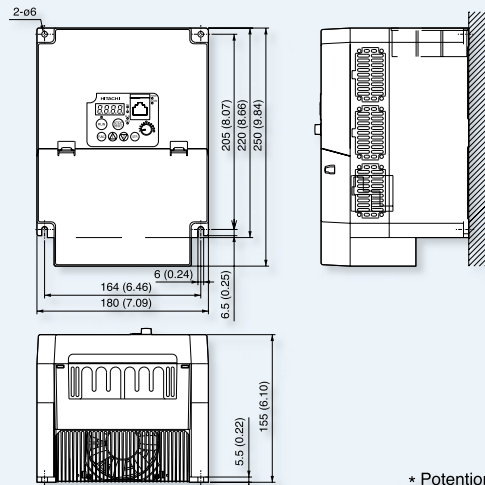

* Potentiometer knob can be removed.

Operation and Programming

L200 Series can be easily operated with the integrated digital operator. An operator with copy function is also available as an option.

Parameter Display

Displays frequency, motor current, rotational speed of the motor, and an alarm code.

RUN Key

Press to run the motor.

STOP/RESET Key

Press to stop the drive or reset an alarm.

Function Key

Press to set or monitor a parameter value.

Up/Down Keys

Press up or down to sequence through parameters and functions shown on the display, and increment/decrement values.

Power LED

Lights when the power input to the drive is ON.

Display Unit LEDs

Indicates the unit associated with the parameter display.

Monitor LEDs

Shows drive's status.

Potentiometer

Store Key

Press to write the new value to the EEPROM.



1. Setting the maximum output frequency

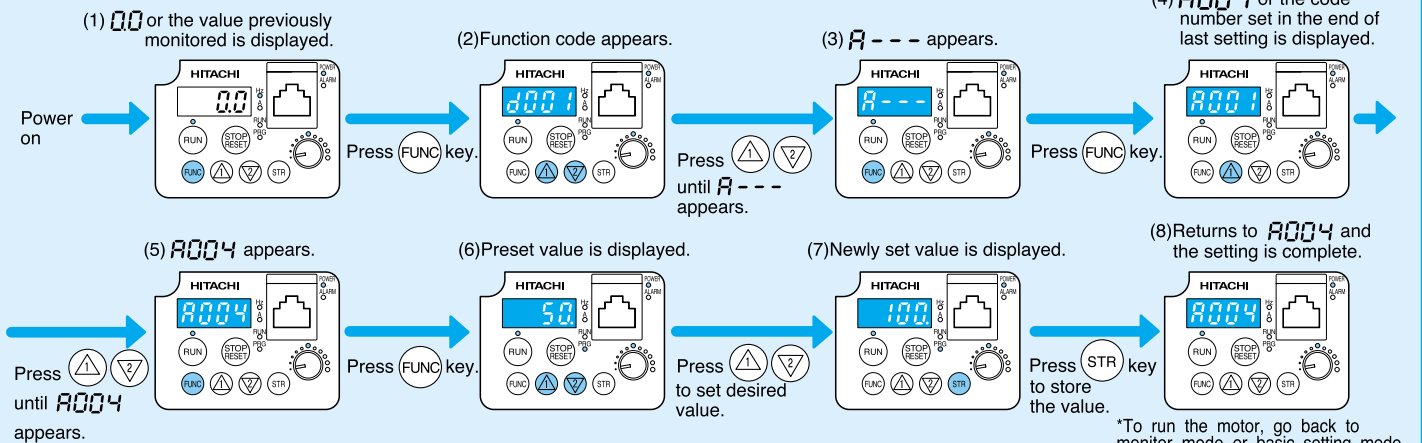

2. Running the motor (by potentiometer)

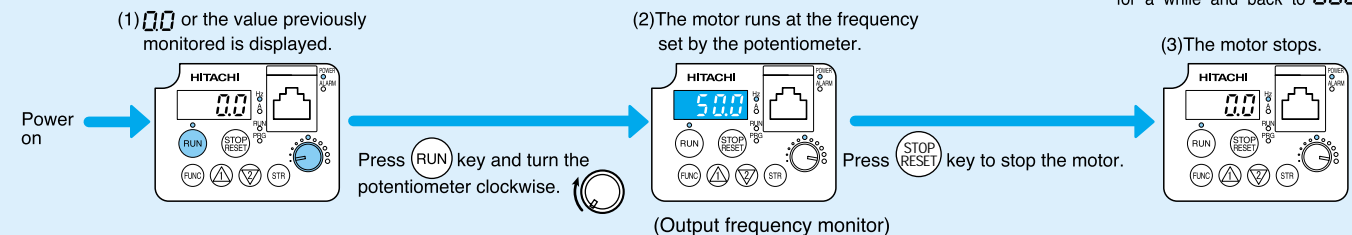

3. Monitoring output current value

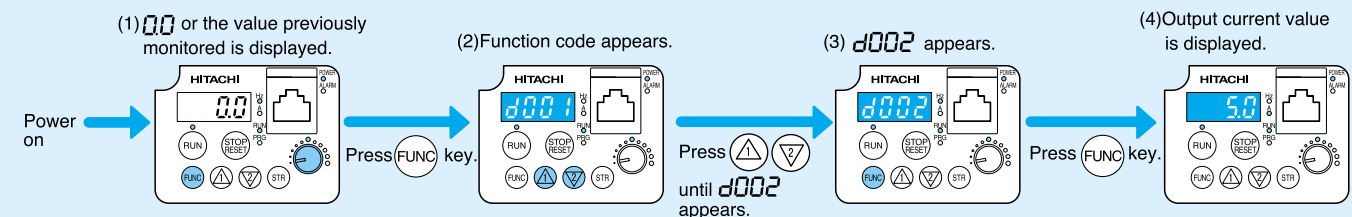

Operation / Terminal Functions

Hardware switches

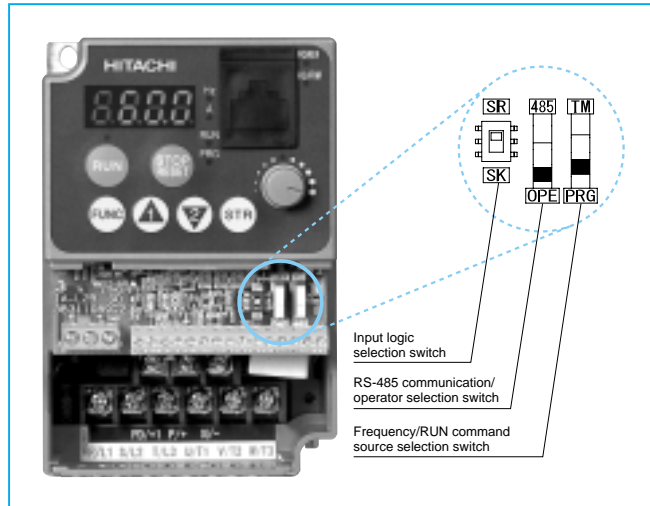

Switch symbol	Switch Name	Switch Name Description	
SR/SK	Input logic selection switch	SR [default]	Source logic
		SK	Sink logic
485/OPE	RS-485 communication/key pad selection switch	485	RS-485 communication via Modbus protocol
		OPE [default]	Keypad (option)
TM/PRG	Frequency/RUN command input switch	TM	Input from control terminal Frequency source: Analog input (O, OI) Run command source: FW and/or RV terminal (FW and/or RV must be assigned to input terminal)
		PRG [default]	Input from source defined with keypad program Frequency source: Potentiometer (default) Run command source: RUN key onkeypad

Note 1: Polarity of the PCS terminal is changed by setting the input logic selection switch.
Note 2: The standard keypad (OPE-SRmini) can be used either the switch is set to 485 or OPE.

Terminal Description

Terminal Symbol

Terminal Symbol	Terminal Name
L1,L2,N/L3	Main power supply input terminals
U/T1,V/T2,W/T3	Inverter output terminals
+1,+	DC reactor connection terminals
+ -	External braking unit connection terminals
⊕	Ground connection terminal

Screw Diameter and Terminal Width

Model	Screw diameter (mm)	Terminal width W (mm)
002 - 004NFU/005NFEF	M3.5	7.6
007- 022NFEF,037LFU	M4	10
004 - 040HFU/HFEF	M4	10
055-075LFU/HFU/HFEF	M5	13

Control circuit terminals

Terminal arrangement

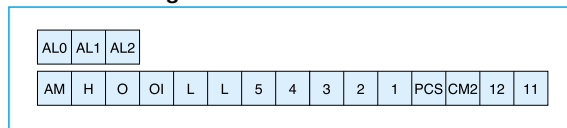

Terminal arrangement

• L200-002NFEF/NFU,-004NFEF/NFU,-005NFEF

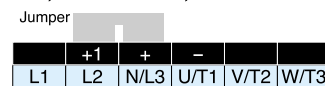

• L200-007NFEF-022NFEF,-037LFU,-004HFEF/HFU-040HFEF/HFU

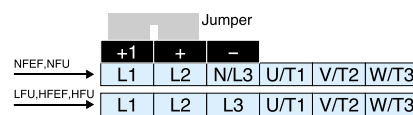

• L200-055LFU,-075LFU,-055HFEF/HFU,-075HFEF/HFU

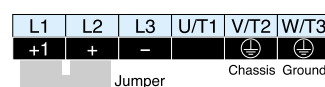

Terminal function

Terminal name	Description	Ranges and Notes	
Input/monitor signals	AM	Voltage analog output	0 to 10V DC, 1mA max.
	L	Common for inputs	-
	PCS	+24V power for inputs	24V DC, 100mA max.
	5	Intelligent (programmable) input terminals, selection from: FW(Forward), RV(Reverse), CF1-CF4(Multispeed command), JG(Jogging), DB(External DC braking), SET(Second motor constants setting), 2CH(Second accel./decel.), FRS(Free-run stop), EXT(External trip), USP(Unattended start protection), SFT(Software lock), AT(Analog input selection), RS(Reset), PTC(Thermistor input), STA(3-wire start), STP(3-wire stop), F/R(3-wire fwd./rev.), PID(PID On/Off), PIDC(PID reset), UP/DWN(Remote-controlled accel./decel.), UDC(Remote-controlled data clearing), OPE(Operator control), ADD(Frequency setpoint), F-TM(Force terminal enable) or NO(Not selected).	
	4		
	3		
	2		
Frequency setting	H	+10V analog reference	10V DC, 10mA max
	O	Analog input, voltage	0 to 10V DC, input impedance 10kohm
	OI	Analog input, current	4 to 20mA DC, input impedance 250ohm
	L	Common for inputs	-
Output signals	12	Intelligent (programmable) output terminals, selection from: RUN(run signal), FA1(Frequency arrival type 1 - constant speed), FA2(Frequency arrival type 2 -over-frequency), OL(overload advance notice signal), OD(Output deviation for PID control), AL(alarm signal), DC(Wire brake detect on analog input), FBV(Feedback voltage comparison), NDc(Network Disconnection), LOG(Logic operation result).	Open collector output L level at operation (ON) 27V DC, 50mA max.
	11		
	CM2	Common for intelligent output terminals	-
Relay output	AL2	Relay contact (alarm output) terminals (programmable, function is selectable same as intelligent output terminals).	AC250V 2.0A (Resistive load) 0.2A (cosφ=0.4)
	AL1		DC30V 3.0A (Resistive load) 0.6A (cosφ=0.4)
	AL0		(minimum) AC100V 10mA DC 5V 100mA

Function List

Monitoring and main profile parameters

[✓: Allowed
[X: Not allowed]

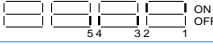
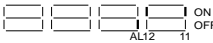
Function Code	Name	Range	Default	Unit	Run mode edit
d001	Output frequency monitor	0.0 to 400.0	—	Hz	—
d002	Output current monitor	0.0 to 999.9	—	A	—
d003	Rotation direction monitor	F(Forward)/o(Stop)/r(Reverse)	—	—	—
d004	Process variable, PID feedback monitor	0.00 to 99.99/100.0 to 999.9/1000. to 9999.	—	—	—
d005	Intelligent input terminal status	 e.g. : 1,2 : ON 3,4,5 : OFF	—	—	—
d006	Intelligent output terminal status	 e.g. : 11,12 : ON AL : OFF	—	—	—
d007	Scaled output frequency monitor	0.00 to 99.99/100.0 to 999.9/1000. to 9999./1000 to 9999(10000 to 99999)	—	—	—
d013	Output voltage monitor	0.0 to 600.0	—	V	—
d016	Cumulative operation RUN time monitor	0. to 9999./1000 to 9999/10000 to 99990	—	hr	—
d017	Cumulative power-on time monitor	0. to 9999./1000 to 9999/10000 to 99991	—	hr	—
d080	Trip counter	0. to 9999.	—	times	—
d081	Trip monitor 1		—	—	—
d082	Trip monitor 2	Displays trip event information	—	—	—
d083	Trip monitor 3		—	—	—
F001	Output frequency setting	0.0/start freq. to 400.0	0.0	Hz	✓
F002	Acceleration time (1) setting	0.01 to 99.99/100.0 to 999.9/1000. to 3000.	10.0	sec	✓
F202	Acceleration time (2) setting	0.01 to 99.99/100.0 to 999.9/1000. to 3000.	10.0	sec	✓
F003	Deceleration time (1) setting	0.01 to 99.99/100.0 to 999.9/1000. to 3000.	10.0	sec	✓
F203	Deceleration time (2) setting	0.01 to 99.99/100.0 to 999.9/1000. to 3000.	10.0	sec	✓
F004	Keypad Run key routing	00(Forward)/01(Reverse)	00	—	X
A--	A Group: Standard functions				
b--	b Group: Fine-tuning functions				
C--	C Group: Intelligent terminal functions				
H--	H Group: Motor constants functions				

A Group: Standard functions

Function Code	Name	Range	Default		Unit	Run mode edit		
			-EF(CE)	-U(UL)				
Basic setting	A001	Frequency source setting	00(Keypad potentiometer)/01(Control terminal)/02(Function F001 setting)/03(RS485)/10(Calculate function output)		01	00	—	X
	A002	Run command source setting	01(Control terminal)/02(Run key on keypad)/03(RS485)		01	02	—	X
	A003	Base frequency setting	30 to maximum freq.		50.	60.	Hz	X
	A203	Base frequency setting, 2nd motor	30 to maximum freq.		50.	60.	Hz	X
	A004	Maximum frequency setting	30 to 400		50.	60.	Hz	X
Analog input setting	A204	Maximum frequency setting, 2nd motor	30 to 400		50.	60.	Hz	X
	A005	[AT] selection	00(O/OI)/01(disable)/02(O/VR)/03(OI/VR)		0.0	0.0	—	X
	A011	[O]-[L] input active range start frequency	0.0 to maximum freq.		0.0	0.0	Hz	X
	A012	[O]-[L] input active range end frequency	0.0 to maximum freq.		0.	0.	Hz	X
	A013	[O]-[L] input active range start voltage	0 to 100		0.	0.	%	X
	A014	[O]-[L] input active range end voltage	0 to 100		100	100.	%	X
	A015	[O]-[L] input start frequency enable	00(use set value)/01(use 0 Hz)		01	01	—	X
Multi-speed and jogging	A016	External frequency filter time constant	1 to 8		2.	8.	—	✓
	A020 - A035	Multi-speed frequency setting (0-15)	0.0/start freq. to maximum freq.		0.0	0.0	Hz	✓
	A220	Multi-speed frequency (2nd), 0	0.0/start freq. to maximum freq.		0.0	0.0	Hz	✓
	A038	Jog frequency setting	0.00/start freq. to 9.99		1.00	1.00	Hz	✓
	A039	Jog stop mode	00(free-run stop)/01(deceleration and stop)/02(DC braking)		00	00	—	X
V/f Characteristic	A041	Torque boost select	00(Manual)/01(Automatic)		00	00	—	✓
	A241	Torque boost select, 2nd motor	00(Manual)/01(Automatic)		00	00	—	✓
	A042	Manual torque boost value	0.0 to 20.0		5.0	5.0	%	✓
	A242	Manual torque boost value, 2nd motor	0.0 to 20.0		0.0	0.0	%	✓
	A043	Manual torque boost frequency adjustment	0.0 to 50.0		3.0	3.0	%	✓
	A243	Manual torque boost frequency adjustment, 2nd motor	0.0 to 50.0		0.0	0.0	%	✓
	A044	V/f characteristic curve selection	00(VC)/01(Reduced torque)		00	00	—	X
	A244	V/f characteristic curve selection, 2nd motor	00(VC)/01(Reduced torque)		00	00	—	X
DC braking	A045	V/f gain setting	20 to 100		100.	100.	%	✓
	A051	DC braking enable	00(Disable)/01(Enable)		00	00	—	X
	A052	DC braking frequency setting	Start freq. to 60.0		0.5	0.5	Hz	X
	A053	DC braking wait time	0.0 to 5.0		0.0	0.0	sec	X
	A054	DC braking force during deceleration	0. to 100.		0.	0.	%	X
	A055	DC braking time for deceleration	0.0 to 60.0		0.0	0.0	sec	X
Frequency limit and jump frequency	A056	DC braking / edge or level detection for [DB] input	00(Edge)/01(Level)		01	01	—	X
	A061	Frequency upper limit setting	0.0/Freq. lower limit setting to maximum freq.		0.0	0.0	Hz	X
	A261	Frequency upper limit setting, 2nd motor	0.0/Freq. lower limit setting (2nd) to maximum freq. (2nd)		0.0	0.0	Hz	X
	A062	Frequency lower limit setting	0.0/Start freq. to freq. upper limit setting		0.0	0.0	Hz	X
	A262	Frequency lower limit setting, 2nd motor	0.0/Start freq. (2nd) to freq. upper limit setting (2nd)		0.0	0.0	Hz	X
	A063	Jump (center) frequency setting 1	0.0 to 400.		0.0	0.0	Hz	X
	A064	Jump (hysteresis) frequency setting 1	0.0 to 10.0		0.5	0.5	Hz	X
	A065	Jump (center) frequency setting 2	0.0 to 400.		0.0	0.0	Hz	X
	A066	Jump (hysteresis) frequency setting 2	0.0 to 10.0		0.5	0.5	Hz	X
	A067	Jump (center) frequency setting 3	0.0 to 400.		0.0	0.0	Hz	X
A068	Jump (hysteresis) frequency setting 3	0.0 to 10.0		0.5	0.5	Hz	X	

Function List

A Group: Standard functions

✓: Allowed
✗: Not allowed

Function Code	Name	Range	Default		Unit	Run mode edit		
			-EF	-U				
PID Control	A071	PID Enable	00(Disable)/01(Enable)		00	00	-	✗
	A072	PID proportional gain	0.2 to 5.0		1.0	1.0	-	✓
	A073	PID integral time constant	0.0 to 150.0		1.0	1.0	sec	✓
	A074	PID derivative time constant	0.00 to 100.0		0.0	0.0	sec	✓
	A075	PV scale conversion	0.01 to 99.99		1.00	1.00	-	✗
	A076	PV source setting	00([O] terminal)/01([O] terminal)/02(RS485)/10(Calculation result)		00	00	-	✗
	A077	Reverse PID action	00(OFF)/01(ON)		00	00	-	✗
	A078	PID output limit	0.0 to 100.0		0.0	0.0	%	✗
AVR function	A081	AVR function select	00(Enable)/01(Disable)/02(Enabled except during deceleration)		00	00	-	✗
	A082	AVR voltage select	200V class: 200/215/220/230/240 400V class: 380/400/415/440/460/480		230/400	230/460	V	✗
Operation mode and acc./dec. function	A092	Acceleration (2) time setting	0.01 to 99.99/100.0 to 999.9/1000. to 3000.		15.00	15.00	sec	✓
	A292	Acceleration (2) time setting, 2nd motor	0.01 to 99.99/100.0 to 999.9/1000. to 3000.		15.00	15.00	sec	✓
	A093	Deceleration (2) time setting	0.01 to 99.99/100.0 to 999.9/1000. to 3000.		15.00	15.00	sec	✓
	A293	Deceleration (2) time setting, 2nd motor	0.01 to 99.99/100.0 to 999.9/1000. to 3000.		15.00	15.00	sec	✓
	A094	Select method to switch to Acc2/Dec2 profile	00(2CH from input terminal)/01(transition freq.)		00	00	-	✗
	A294	Select method to switch to Acc2/Dec2 profile, 2nd motor	00(2CH from input terminal)/01(transition freq.)		00	00	-	✗
	A095	Acc1 to Acc2 frequency transition point	0.0 to 400.0		0.0	0.0	Hz	✗
	A295	Acc1 to Acc2 frequency transition point, 2nd motor	0.0 to 400.0		0.0	0.0	Hz	✗
	A096	Dec1 to Dec2 frequency transition point	0.0 to 400.0		0.0	0.0	Hz	✗
	A296	Dec1 to Dec2 frequency transition point, 2nd motor	0.0 to 400.0		0.0	0.0	Hz	✗
External freq. tuning	A097	Acceleration curve selection	00(Linear)/01(S-curve)		00	00	-	✗
	A098	Deceleration curve selection	00(Linear)/01(S-curve)		00	00	-	✗
	A101	[OI]-[L] input active range start frequency	0.0 to maximum freq.		0.0	0.0	Hz	✗
	A102	[OI]-[L] input active range end frequency	0.0 to maximum freq.		0.0	0.0	Hz	✗
	A103	[OI]-[L] input active range start current	0. to 100.		0.	0.	%	✗
Frequency calculation	A104	[OI]-[L] input active range end current	0. to 100.		100.	100.	%	✗
	A105	[OI]-[L] input start frequency enable	00(Use setting value)/01(0Hz)		01	01	-	✗
	A141	A input select for calculate function	01(Keypad potentiometer)		02	02	-	✗
	A142	B input select for calculate function	02(O input)/03(OI input)/04(RS485)		03	03	-	✗
	A143	Calculation symbol	00(A141+A142)/01(A141-A142)/02(A141*A142)		00	00	-	✗
	A145	ADD frequency	0.0 to 400.0		0.0	0.0	Hz	✓
	A146	ADD direction select	00(plus)/01(minus)		00	00	-	✗

b Group: Fine-tuning functions

Function Code	Name	Range	Default		Unit	Run mode edit		
			-EF	-U				
Restart after instantaneous power failure	b001	Selection of automatic restart mode	00(Alarm output)/01(Restart at 0Hz)/02(Resume after freq. matching)/03(Resume freq. matching then trip)		00	00	-	✗
	b002	Allowable under-voltage power failure time	0.3 to 25.0		1.0	1.0	sec	✗
	b003	Retry wait time before motor restart	0.3 to 100.0		1.0	1.0	sec	✗
	b004	Instantaneous power failure / under-voltage trip alarm enable	00(Disable)/01(Enable)		00	00	-	✗
	b005	Number of restarts on power failure / under-voltage trip events	00(Restart 16 times)/01(Always restart)		00	00	-	✗
	b012	Electronic thermal setting	0.2*Rated current to 1.2*Rated current		Rated current	Rated current	A	✗
	b212	Electronic thermal setting, 2nd motor	0.2*Rated current to 1.2*Rated current		Rated current	Rated current	A	✗
Overload restriction	b013	Electronic thermal characteristic	00(Reduced torque)/01(Constant torque)/02(Reduced torque 2)		01	01	-	✗
	b213	Electronic thermal characteristic, 2nd motor	00(Reduced torque)/01(Constant torque)/02(Reduced torque 2)		01	01	-	✗
	b021	Overload restriction operation mode	00(Disable)/01(Enable)/02(Enable for during acceleration)		01	01	-	✗
	b022	Overload restriction setting	0.2*Rated current to 1.5*Rated current		1.5*Rated current	1.5*Rated current	A	✗
Lock	b023	Deceleration rate at overload restriction	0.1 to 30.0		1.0	30.0	sec	✗
	b031	Software lock mode selection	00([SFT] input blocks all edits)/01([SFT] input blocks edits except F001 and Multispeed parameters)/02(No access to edits)/03(No access to edits except F001 and Multi-speed parameters)		01	01	-	✗
	b080	[AM] terminal analog meter adjustment	0. to 255.		100.	100.	-	✓
Others	b082	Start frequency adjustment	0.5 to 9.9		0.5	0.5	Hz	✗
	b083	Carrier frequency setting	2.0 to 14.0		5.0	5.0	kHz	✗
	b084	Initialization mode (parameters or trip history)	00(Trip history clear)/01(Parameter initialization)/02(Trip history clear and parameter initialization)		00	00	-	✗
	b085	Country code for initialization	00(JP)/01(CE)/02(US)		01	02	-	✗
	b086	Frequency scaling conversion factor	0.1-99.9		1.0	1.0	-	✓
	b087	STOP key enable	00(Enable)/01(Disable)		00	00	-	✗
	b088	Restart mode after FRS	00(Restart from 0Hz)/01(Restart with frequency detection)		00	00	-	✗
	b089	Monitor display select for networked inverter	01(output frequency)/02(output current)/03(rotation direction)/04(PV PID feedback)/05(Input terminal status)/06(Output terminal status)/07(Scaled output frequency)		01	01	-	✗
	b091	Stop mode selection	00(Deceleration and stop)/01(Free-run stop)		00	00	-	✗
	b130	Over-voltage LAD STOP enable	00(Disable)/01(Enable)		00	00	-	✗
	b150	Carrier mode	00(Disable)/01(Enable)		00	00	-	✗

Function List

C Group: Intelligent terminal functions

✓: Allowed
✗: Not allowed

Function Code		Name	Range	Default		Unit	Run mode edit
				-EF	-U		
Intelligent input terminal	C001	Terminal [1] to [5] function	00(FW:Forward), 01(RV:Reverse), 02-05(CF1-CF4:Multispeed command), 06(JG:Jogging), 07(DB:External DC braking), 08(SET:Second motor constants setting), 09(2CH:Second accel./decel.), 11(FRS:Free-run stop), 12(EXT:External trip), 13(USP:Unattended start protection), 15(SFT:Software lock), 16(AT:Analog input selection), 18(RS:Reset), 19(PTC:Thermistor input), 20(STA:3-wire start), 21(STP:3-wire stop), 22(F/R:3-wire fwd./rev.), 23(PID:PID On/Off), 24(PIDC:PID reset), 27(UP:Remote-controlled accel.), 28(DWN:Remote-controlled decel.), 29(UDC:Remote-controlled data clearing), 31(OPE:Operator control), 50(ADD: Frequency setpoint), 51(F-TM: Force terminal enable), 255(NO:Not selected)	00	00	–	✗
	C002			01	01	–	✗
	C003			02	16	–	✗
	C004			03	13	–	✗
	C005			18	09	–	✗
	C011-C015	Terminal [1] to [5] active state	00(NO)/01(NC)	00	00	–	✗
Intelligent input terminal	C021	Terminal [11] and [12] function	00(RUN:run signal), 01(FA1:Frequency arrival type 1 - constant speed), 02(FA2:Frequency arrival type 2 - over-frequency), 03(OL:overload advance notice signal), 04(OD:Output deviation for PID control), 05(AL:alarm signal), 06(DC:Wire brake detect on analog input), 07(FBV: Feedback voltage comparison), 08(NDc: Network Disconnection), 09(LOG: Logic operation result)	01	01	–	✗
	C022			00	00	–	✗
	C026	Alarm relay function		05	05	–	✗
	C028	[AM] signal selection	00(Output frequency)/01(Output current)	00	00	–	✗
	C031, C032	Terminal [11] and [12] active state	00(NO)/01(NC)	00	00	–	✗
	C036	Alarm relay active state	00(NO)/01(NC)	01	01	–	✗
	C041	Overload level setting	0.0*Rated current to 2.0*Rated current	Rated current	Rated current	A	✗
	C042	Frequency arrival setting for acceleration	0.0 to 400.0	0.0	0.0	Hz	✗
	C043	Frequency arrival setting for deceleration	0.0 to 400.0	0.0	0.0	Hz	✗
	C044	PID deviation level setting	0.0 to 100.0	3.0	3.0	%	✗
	Serial communication	C052	Feedback comparison upper level	0.0 to 100.0	100	100	%
C053		Feedback comparison lower level	0.0 to 100.0	0	0	%	✗
C071		Communication speed selection	04(4800bps)/05(9600bps)/06(19200bps)	06	04	–	✗
C072		Node allocation	1. to 32.	1.	1.	–	✗
C074		Communication parity selection	00(No parity)/01(Even parity)/02(Odd parity)	00	00	–	✗
C075		Communication stop bit selection	1(1-bit)/2(2-bit)	1	1	bit	✗
C076		Communication error mode	00(Trip)/01(Trip after deceleration stop)/02(Disable)/03(FRS)/04(Deceleration stop)	02	02	–	✗
C077		Communication error time	0.00-99.99	0.00	0.00	sec	✗
C078		Communication wait time	0. to 1000.	0.	0.	msec	✗
Analog meter setting		C081	[O] input span calibration	0. to 200.	100.	100.	%
	C082	[OL] input span calibration	0. to 200.	100.	100.	%	✓
	C085	Thermistor input tuning	0.0 to 200.0	100.0	100.0	%	✓
	C086	[AM] terminal offset tuning	0.0 to 10.0	0.0	0.0	V	✓
Others	C091	Reserved (for factory adjustment)	00 (must not be changed)	00	00	–	✓
	C101	Up/Down memory mode selection	00(Clear last frequency)/01(Keep last frequency adjusted by UP/DWN)	00	00	–	✗
	C102	Reset mode selection	00(Cancel trip state at input signal ON transition)/01(Cancel trip state at signal OFF transition)/02(Cancel trip state at input signal ON transition)	00	00	–	✗
	C141	Logic operation source 1	00(RUN)/01(FA1)/02(FA2)/03(OL)/04(OD)	0	0	–	✗
	C142	Logic operation source 2	05(AL)/06(Dc)/07(FBV)/08(NDc)	1	1	–	✗
	C143	Logic operation select	00(AND)/01(OR)/02(XOR)	0	0	–	✗
	C144	ON delay time, output terminal 11	0.0 to 100.0	0.0	0.0	sec	✗
	C145	OFF delay time, output terminal 11	0.0 to 100.0	0.0	0.0	sec	✗
	C146	ON delay time, output terminal 12	0.0 to 100.0	0.0	0.0	sec	✗
	C147	OFF delay time, output terminal 12	0.0 to 100.0	0.0	0.0	sec	✗
	C148	ON delay time, relay	0.0 to 100.0	0.0	0.0	sec	✗
	C149	OFF delay time, relay	0.0 to 100.0	0.0	0.0	sec	✗

H Group: Motor constants functions

Function Code		Name	Range	Default		Unit	Run mode edit
				-EF	-U		
Motor constants and gain	H003	Motor capacity, 1st motor	JP,US: 0.2/0.4/0.75/1.5/2.2/3.7/5.5/7.5/11.0	Factory set	Factory set	kW	✗
	H203	Motor capacity, 2nd motor	CE: 0.2/0.4/0.55/0.75/1.1/1.5/2.2/3.0/4.0/5.5/7.5/11.0			kW	✗
	H004	Motor poles setting, 1st motor		4	4	poles	✗
	H204	Motor poles setting, 2nd motor	2/4/6/8	4	4	poles	✗
	H006	Motor stabilization constant, 1st motor		100	100	–	✓
	H206	Motor stabilization constant, 2nd motor	0. to 255.	100	100	–	✓

Protective Functions

Error Codes

Name	Cause(s)	Display on digital operator	Display on remote operator/copy unit	
Over current	The inverter output was short-circuited, or the motor shaft is locked or has a heavy load. These conditions cause excessive current for the inverter, so the inverter output is turned OFF.	While at constant speed	E 01	OC.Drive
		During deceleration	E 02	OC.Decel
		During acceleration	E 03	OC.Accel
		Others	E 04	Over.C
Overload protection *1	When a motor overload is detected by the electronic thermal function, the inverter trips and turns OFF its output.	E 05	Over.L	
Over voltage protection	When the DC bus voltage exceeds a threshold, due to regenerative energy from the motor.	E 07	Over.V	
EEPROM error *2,3	When the built-in EEPROM memory has problems due to noise or excessive temperature, the inverter trips and turns OFF its output to the motor.	E 08	EEPROM	
Under-voltage error	A decrease of internal DC bus voltage below a threshold results in a control circuit fault. This condition can also generate excessive motor heat or cause low torque. The inverter trips and turns OFF its output.	E 09	Under.V	
CPU error	A malfunction in the built-in CPU has occurred, so the inverter trips and turns OFF its output to the motor.	E 11	CPU	
		E 22	COMM.ERR	
External trip	A signal on an intelligent input terminal configured as EXT has occurred. The inverter trips and turns OFF the output to the motor.	E 12	EXTERNAL	
USP *4	When the Unattended Start Protection (USP) is enabled, an error occurred when power is applied while a Run signal is present. The inverter trips and does not go into Run Mode until the error is cleared.	E 13	USP	
Ground fault *5	The inverter is protected by the detection of ground faults between the inverter output and the motor during powerup tests. This feature protects the inverter, and does not protect humans.	E 14	GND.Flt	
Input over-voltage	When the input voltage is higher than the specified value, it is detected 100 seconds after powerup and the inverter trips and turns OFF its output.	E 15	OV.SRC	
Inverter thermal trip	When the inverter internal temperature is above the threshold, the thermal sensor in the inverter module detects the excessive temperature of the power devices and trips, turning the inverter output OFF.	E 21	OH FIN	
Driver error	An internal inverter error has occurred at the safety protection circuit between the CPU and main driver unit. Excessive electrical noise may be the cause. The inverter has turned OFF the IGBT module output.	E 30	DRIVE	
Thermistor	When a thermistor is connected to terminals [PTC] and [L1] and the inverter has sensed the temperature is too high, the inverter trips and turns OFF the output.	E 35	TH	
Communications error	The inverter's watchdog timer for the communications network has timed out.	E 60	COMM	

Note 1: Reset operations acceptable 10 seconds after the trip.

Note 2: If an EEPROM error (E08) occurs, be sure to confirm the parameter data values are still correct.

Note 3: EEPROM error may occur at power-on after shutting down the power while copying data with remote operator or initializing data. Shut down the power after completing copy or initialization.

Note 4: USP error occurs at resetting trip after under-voltage error (E09) if USP is enabled. Reset once more to recover.

Note 5: Ground fault error (E14) cannot be released with resetting. Shut the power and check wiring.

How to access the details about the present fault

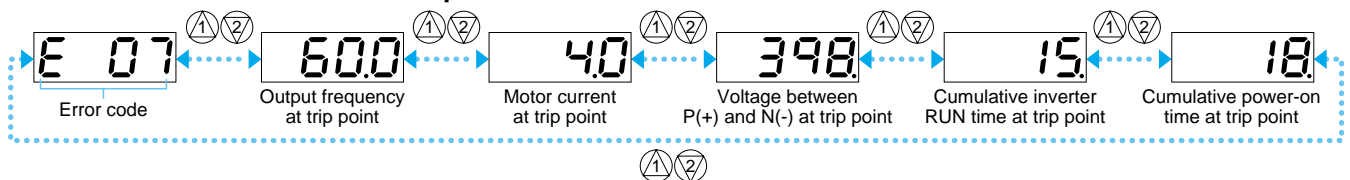

Connecting Diagram

Source type logic

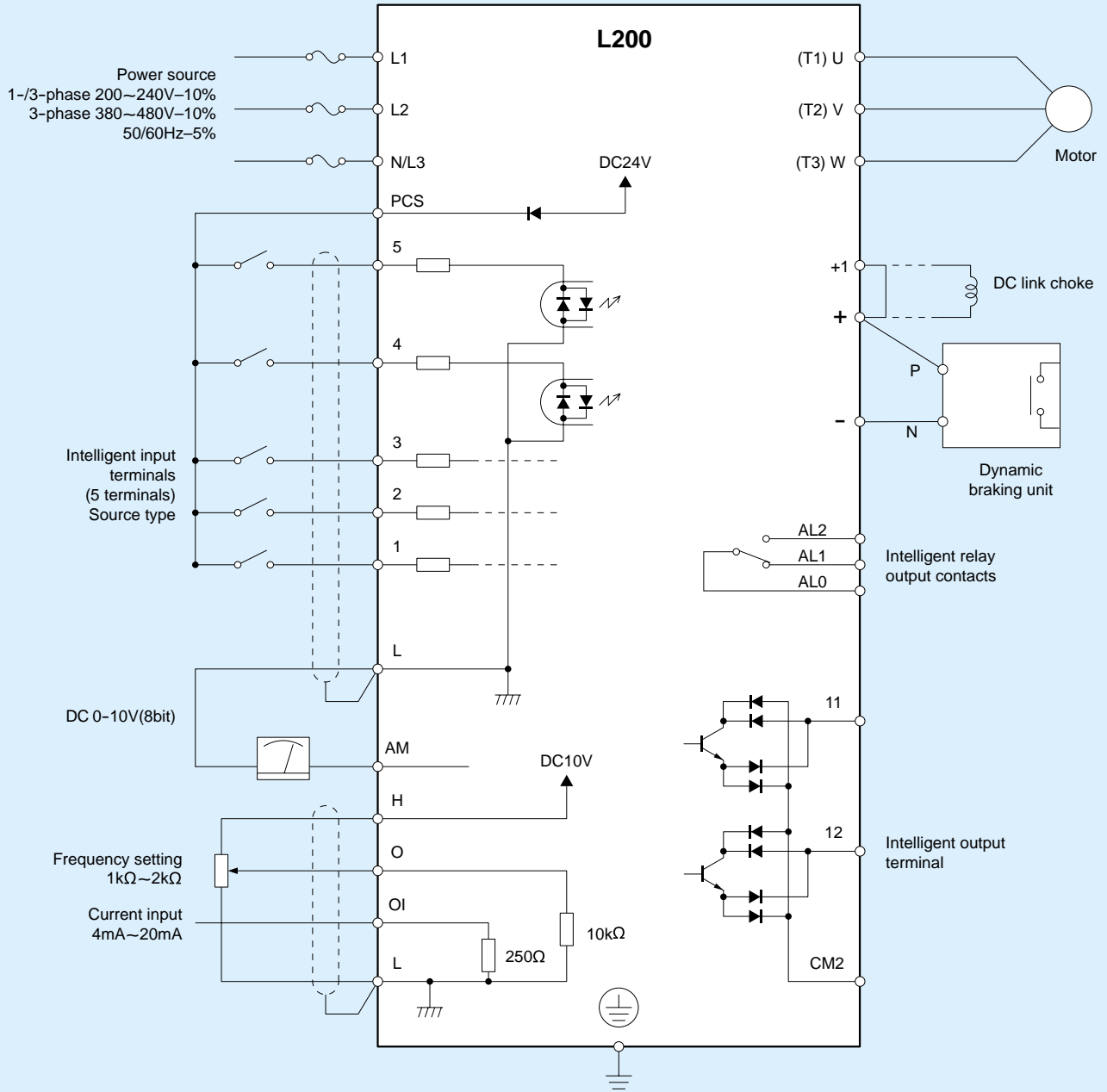

Note 1: Common terminals are depend on logic.

Terminal	1,2,3,4,5	H,O,OI	11,12
Common	Sink logic : L	L	CM2
	Source logic : PCS		

Note 2: Choose proper inverter input volotage rating.

Wiring and Accessories

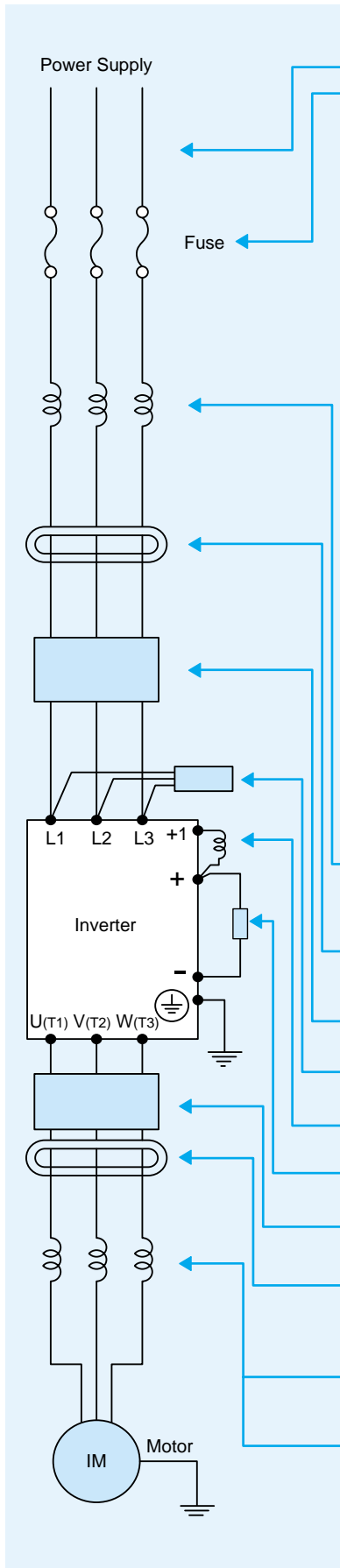

Input Voltage	Applicable Motor (kW(HP))	Model	Wiring		Signal Lines	Fuse (Class J)
			Power Lines			
			AWG	mm ²		
200V	0.2(1/4)	L200-002NFU/NFEF	16	1.25	0.14 to 0.75mm ² shielded wire	10
	0.4(1/2)	L200-004NFU/NFEF	16	1.25		10
	0.55(3/4)	L200-005NFEF	16	1.25		10
	0.75(1)	L200-007NFU/NFEF	14	2.0		15
	1.1(1.5)	L200-011NFEF	14	2.0		15
	1.5(2)	L200-015NFU/NFEF	12	2.0		20(single ph.) 15(three ph.)
	2.2(3)	L200-022NFU/NFEF	10	2.0		30(single ph.) 20(three ph.)
	3.7(5)	L200-037LFU	12	3.5		30
	5.5(7.5)	L200-055LFU	10	5.5		40
	7.5(10)	L200-075LFU	8	8.4		50
400V	0.4(1/2)	L200-004HFU/HFEF	16	1.25	0.14 to 0.75mm ² shielded wire	3
	0.75(1)	L200-007HFU/HFEF	16	1.25		6
	1.5(2)	L200-015HFU/HFEF	16	1.25		10
	2.2(3)	L200-022HFU/HFEF	16	1.25		10
	3(4)	L200-030HFEF	14	2.0		15
	3.7(5)	L200-040HFU/HFEF	14	2.0		15
	5.5(7.5)	L200-055HFU/HFEF	12	3.5		20
	7.5(10)	L200-075HFU/HFEF	12	3.5		25

Note 1: Field wiring connection must be made by a UL and c-UL listed closed-loop terminal connector sized for the wire gauge involved. Connector must be fixed using the crimping tool specified by the connector manufacturer.

Note 2: Be sure to use large wire gauges for power wiring if the distance exceeds 20m (66ft).

Note 3: Use 0.75mm² wire for the relay terminals (AL0, AL1 and AL2) signal wire.

Name	Function
Input side AC reactor	This is useful in suppressing harmonics induced on the power supply lines, or when the main power voltage imbalance exceeds 3% (and power source capacity is more than 500kVA), or to smooth out line fluctuations. It also improves the power factor.
Radio noise filter	Electrical noise interference may occur on nearby equipment such as a radio receiver. This magnetic choke filter helps reduce radiated noise (can also be used on output).
EMC filter	Reduces the conducted noise on the power supply wiring generated by the inverter. Connect to the inverter input side.
Radio noise filter (Capacitor filter)	This capacitor filter reduces radiated noise from the main power wires in the inverter input side.
DC link choke	Suppresses harmonics generated by the inverter.
Braking unit	This is useful for increasing the inverter's control torque for high duty-cycle (on-off) applications, and improving the decelerating capability.
Output side noise filter	Reduces radiated noise from wiring in the inverter output side.
Radio noise filter	Electrical noise interference may occur on nearby equipment such as a radio receiver. This magnetic choke filter helps reduce radiated noise (can also be used on input).
AC reactor	This reactor reduces the vibration in the motor caused by the inverter's switching waveforms, by smoothing the waveforms to approximate commercial power quality. It is also useful when wiring from the inverter to the motor is more than 10m in length, to reduce harmonics.
LCR filter	Sine wave shaping filter for the output side.

Note: An EMI filter is required for European EMC directive and C-Tick, but the others are not for this purpose.

For Correct Operation

Application to Motors

Application to general-purpose motors

Operating frequency	The overspeed endurance of a general-purpose motor is 120% of the rated speed for 2 minutes (JIS C4,004). For operation at higher than 60Hz, it is required to examine the allowable torque of the motor, useful life of bearings, noise, vibration, etc. In this case, be sure to consult the motor manufacturer as the maximum allowable rpm differs depending on the motor capacity, etc.
Torque characteristics	The torque characteristics of driving a general-purpose motor with an inverter differ from those of driving it using commercial power (starting torque decreases in particular). Carefully check the load torque characteristic of a connected machine and the driving torque characteristic of the motor.
Motor loss and temperature increase	The torque characteristics of driving a general-purpose motor with an inverter differ from those of driving it using commercial power
Noise	When run by an inverter, a general-purpose motor generates noise slightly greater than with commercial power.
Vibration	When run by an inverter at variable speeds, the motor may generate vibration, especially because of (a) unbalance of the rotor including a connected machine, or (b) resonance caused by the natural vibration frequency of a mechanical system. Particularly, be careful of (b) when operating at variable speeds a machine previously fitted with a constant speed motor. Vibration can be minimized by (1) avoiding resonance points using the frequency jump function of the inverter, (2) using a tire-shaped coupling, or (3) placing a rubber shock absorber beneath the motor base.
Power transmission mechanism	Under continued, low-speed operation, oil lubrication can deteriorate in a power transmission mechanism with an oil-type gear box (gear motor) or reducer. Check with the motor manufacturer for the permissible range of continuous speed. To operate at more than 60Hz, confirm the machine's ability to withstand the centrifugal force generated.

Application to special motors

Gear motor	The allowable rotation range of continuous drive varies depending on the lubrication method or motor manufacturer. (Particularly in case of oil lubrication, pay attention to the low frequency range.)
Brake-equipped motor	For use of a brake-equipped motor, be sure to connect the braking power supply from the primary side of the inverter.
Pole-change motor	There are different kinds of pole-change motors (constant output characteristic type, constant torque characteristic type, etc.), with different rated current values. In motor selection, check the maximum allowable current for each motor of a different pole count. At the time of pole changing, be sure to stop the motor. Also see: Application to the 400V-class motor.
Submersible motor	The rated current of a submersible motor is significantly larger than that of the general-purpose motor. In inverter selection, be sure to check the rated current of the motor.
Explosion-proof motor	Inverter drive is not suitable for a safety-enhanced explosion-proof type motor. The inverter should be used in combination with a pressure-proof explosion-proof type of motor. *Explosion-proof verification is not available for L200 Series.
Synchronous (MS) motor High-speed (HFM) motor	In most cases, the synchronous (MS) motor and the high-speed (HFM) motor are designed and manufactured to meet the specifications suitable for a connected machine. As to proper inverter selection, consult the manufacturer.
Single-phase motor	A single-phase motor is not suitable for variable-speed operation by an inverter drive. Therefore, use a three-phase motor.

Application to the 400V-class motor

A system applying a voltage-type PWM inverter with IGBT may have surge voltage at the motor terminals resulting from the cable constants including the cable length and the cable laying method. Depending on the surge current magnification, the motor coil insulation may be degraded. In particular, when a 400V-class motor is used, a longer cable is used, and critical loss can occur, take the following countermeasures:

- (1) install the LCR filter between the inverter and the motor,
- (2) install the AC reactor between the inverter and the motor, or
- (3) enhance the insulation of the motor coil.

Notes on Use

Drive

Run/Stop	Run or stop of the inverter must be done with the keys on the operator panel or through the control circuit terminal. Do not operate by installing a electromagnetic contactor (MC) in the main circuit.
Emergency motor stop	When the protective function is operating or the power supply stops, the motor enters the free run stop state. When an emergency stop is required or when the motor should be kept stopped, use of a mechanical brake should be considered.
High-frequency run	A max. 400Hz can be selected on the L200 Series. However, a two-pole motor can attain up to approx. 24,000 rpm, which is extremely dangerous. Therefore, carefully make selection and settings by checking the mechanical strength of the motor and connected machines. Consult the motor manufacturer when it is necessary to drive a standard (general-purpose) motor above 60Hz. A full line of high-speed motors is available from Hitachi.

Installation location and operating environment

Avoid installation in areas of high temperature, excessive humidity, or where moisture can easily collect, as well as areas that are dusty, subject to corrosive gasses, mist of liquid for grinding, or salt. Install the inverter away from direct sunlight in a well-ventilated room that is free of vibration. The inverter can be operated in the ambient temperature range from -10 to 50°C. (Carrier frequency and output current must be reduced in the range of 40 to 50°C.)

For Correct Operation

Main power supply

<p>Installation of an AC reactor on the input side</p>	<p>In the following examples involving a general-purpose inverter, a large peak current flows on the main power supply side, and is able to destroy the converter module. Where such situations are foreseen or the connected equipment must be highly reliable, install an AC reactor between the power supply and the inverter. Also, where influence of indirect lightning strike is possible, install a lightning conductor.</p> <p>(A) The unbalance factor of the power supply is 3% or higher. (Note) (B) The power supply capacity is at least 10 times greater than the inverter capacity (the power supply capacity is 500 kVA or more). (C) Abrupt power supply changes are expected.</p> <p>Examples: (1) Several inverters are interconnected with a short bus. (2) A thyristor converter and an inverter are interconnected with a short bus. (3) An installed phase advance capacitor opens and closes.</p> <p>In cases (A), (B) and (C), it is recommended to install an AC reactor on the main power supply side.</p> <p>Note: Example calculation with $V_{RS} = 205V$, $V_{ST} = 201V$, $V_{TR} = 200V$ V_{RS} : R-S line voltage, V_{ST} : S-T line voltage, V_{TR} : T-R line voltage</p> $\text{Unbalance factor of voltage} = \frac{\text{Max. line voltage (min.)} - \text{Mean line voltage}}{\text{Mean line voltage}} \times 100$ $= \frac{V_{RS} - (V_{RS} + V_{ST} + V_{TR})/3}{(V_{RS} + V_{ST} + V_{TR})/3} \times 100 = \frac{205 - 202}{202} \times 100 = 1.5(\%)$
<p>Using a private power generator</p>	<p>An inverter run by a private power generator may overheat the generator or suffer from a deformed output voltage waveform of the generator. Generally, the generator capacity should be five times that of the inverter (kVA) in a PWM control system, or six times greater in a PAM control system.</p>

Notes on Peripheral Equipment Selection

<p>Wiring connections</p>	<p>(1) Be sure to connect main power wires with R(L1), S(L2), and T(L3) terminals (input) and motor wires to U(T1), V(T2), and W(T3) terminals (output). (Incorrect connection will cause an immediate failure.) (2) Be sure to provide a grounding connection with the ground terminal (⊕).</p>
<p>Wiring between inverter and motor</p>	<p>Electromagnetic contactor When an electromagnetic contactor is installed between the inverter and the motor, do not perform on-off switching during running operation.</p> <p>Thermal relay When used with standard applicable output motors (standard three-phase squirrel-cage four-pole motors), the SJ200 Series does not need a thermal relay for motor protection due to the internal electronic protective circuit. A thermal relay, however, should be used: • during continuous running outside a range of 30 to 60 Hz. • for motors exceeding the range of electronic thermal adjustment (rated current). • when several motors are driven by the same inverter; install a thermal relay for each motor. • The RC value of the thermal relay should be more than 1.1 times the rated current of the motor. Where the wiring length is 10 m or more, the thermal relay tends to turn off readily. In this case, provide an AC reactor on the output side or use a current sensor.</p>
<p>Installing a circuit breaker</p>	<p>Install a circuit breaker on the main power input side to protect inverter wiring and ensure personal safety. Choose an inverter-compatible circuit breaker. The conventional type may malfunction due to harmonics from the inverter. For more information, consult the circuit breaker manufacturer.</p>
<p>Wiring distance</p>	<p>The wiring distance between the inverter and the remote operator panel should be 20 meters or less. When this distance is exceeded, use CVD-E (current-voltage converter) or RCD-E (remote control device). Shielded cable should be used on the wiring. Beware of voltage drops on main circuit wires. (A large voltage drop reduces torque.)</p>
<p>Earth leakage relay</p>	<p>If the earth leakage relay (or earth leakage breaker) is used, it should have a sensitivity level of 15 mA or more (per inverter).</p>
<p>Phase advance capacitor</p>	<p>Do not use a capacitor for power factor improvement between the inverter and the motor because the high-frequency components of the inverter output may overheat or damage the capacitor.</p>

High-frequency Noise and Leakage Current

- (1) High-frequency components are included in the input/output of the inverter main circuit, and they may cause interference in a transmitter, radio, or sensor if used near the inverter. The interference can be minimized by attaching noise filters (option) in the inverter circuitry.
- (2) The switching action of an inverter causes an increase in leakage current. Be sure to ground the inverter and the motor.

Lifetime of Primary Parts

Because a DC bus capacitor deteriorates as it undergoes internal chemical reaction, it should normally be replaced every five years. Be aware, however, that its life expectancy is considerably shorter when the inverter is subjected to such adverse factors as high temperatures or heavy loads exceeding the rated current of the inverter. The approximate lifetime of the capacitor is as shown in the figure at the right when it is used 12 hours daily (according to the "Instructions for Periodic Inspection of General-Purpose Inverter" (JEMA)). Also, such moving parts as a cooling fan should be replaced. Maintenance inspection and parts replacement must be performed by only specified trained personnel.

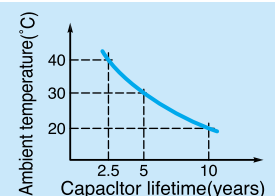

Precaution for Correct Usage

- Before use, be sure to read through the Instruction Manual to insure proper use of the inverter.
- Note that the inverter requires electrical wiring; a trained specialist should carry out the wiring.
- The inverter in this catalog is designed for general industrial applications. For special applications in fields such as aircraft, outer space, nuclear power, electrical power, transport vehicles, clinics, and underwater equipment, please consult with us in advance.
- For application in a facility where human life is involved or serious losses may occur, make sure to provide safety devices to avoid a serious accident.
- The inverter is intended for use with a three-phase AC motor. For use with a load other than this, please consult with us.

Information in this brochure is subject to change without notice.